



MotorLink®
**Intelligent control of
windows**

Window automation

MotorLink® is a state-of-the-art digital data communication technology. It provides improved and accurate control and functionality in connection with any BMS that includes automated windows and natural ventilation

The background of the page is a photograph of a modern building's interior. It features a large, multi-paned glass skylight that allows natural light to filter through. The light creates a series of sharp, geometric shadows on the dark floor below, forming a pattern of triangles and rectangles. The architecture is clean and minimalist, with dark structural elements framing the glass. The overall atmosphere is bright and contemporary.

Almost all kinds of Building Management Systems (BMS) use a subsystem to transfer data between the different devices in the system. These subsystems, that transfer data, are normally called a “Communication Bus” – or simply a “bus”. Some of these bus systems are owned and used by the manufacturer only. But a number of standard (open) bus systems have been developed and have become increasingly common. WindowMaster has developed a range of devices (MotorControllers) that interface between the intelligent WindowMaster actuators and the BMS systems through open bus standards such as KNX, LON, BACnet and Modbus.

Content

- 4 Intelligent control of window actuators
- 6 Automatic window control
- 8 MotorLink® features
- 10 MotorLink® technology
- 12 Components for a MotorLink® solution
- 14 Smoke ventilation
- 15 Actuator variations on a MotorLink® Motorline
- 16 Basic ventilation principles
- 18 Recommendations for design with natural ventilation
- 19 Research and development towards a sustainable indoor climate



Intelligent control of window actuators

The demand for automated and intelligent facades has grown dramatically over recent years and this development will continue due to the focus on energy consumption and sustainability. Automated windows and roof vents can provide buildings with the benefit of improved indoor climates through natural ventilation as well as being used as part of a smoke ventilation system.

The demand for greater and more intelligent control over these automated windows is increasing, with two way communication from the actuator for actual position feedback and three speed operation becoming standard in many projects.

To make the installation, programming and operation of actuators in co-operation with a BMS-system very easy, WindowMaster has developed a range of controllers and smoke panels.

In these controllers and smoke panels the interface to a BMS-system is based on international (open) standards for bus-communication such as KNX, LON, BACnet or Modbus.



WindowMaster

WindowMaster has delivered solutions for natural ventilation and smoke ventilation to a wide range of buildings across Europe for more than 25 years. This experience and knowledge has enabled WindowMaster to continuously develop products and solutions to provide the optimal control of actuators.

This knowledge has been used in developing the MotorLink® technology and to opening it up to the major bus-communication standards: KNX, LON, BACnet or Modbus.

More information

For additional information or documentation please visit our website windowmaster.com





Automatic window control

The best and most secure indoor climate solution

40% of all energy consumption in Western Europe is for buildings – energy, which is primarily coal based, thus providing high CO₂-emissions. Using an automated system for the control of the windows to provide a good indoor climate, instead of, or as well as, using mechanical ventilation, can be a key factor in reducing the carbon footprint of most buildings.

By utilising the MotorLink® technology and solutions from WindowMaster, the BMS provider can achieve a number of benefits:

Technical

By using the MotorLink® technology the BMS provider will benefit from more accurate and precise control over the openings as well access to an increased number of functions. The MotorLink® controllers interface to the major international bus-communication standards and enable the BMS supplier to quickly and easily programme the required parameters for the windows.

Financial

There is no better way to secure a budget than by choosing tried and tested solutions based on international standards. By using actuators and MotorControllers with MotorLink® technology from WindowMaster, you will not have any concerns about dedicated software development – you just need to set up some parameters for interface to KNX, LON, BACnet or Modbus. That is what we call reduced financial risk.

Security

To choose products from WindowMaster in your solution, you choose a partner that has more than 25 years of experience – not only in actuators and actuator technology, but also in co-operation with many of Europe's window manufacturers. That is what we call security for your solution.

MotorLink® features

WindowMaster has developed and patented a unique technology called MotorLink®. This technology enables a versatile range of functionality in order to fulfil requirements of modern facade design

In control solutions utilizing MotorLink® technology there is digital data communication to every single window actuator.

The large range of functionality available within the MotorLink® technology enables the BMS provider to deliver a more robust, flexible and intelligent control solution to meet the individual project requirements.

1

Position control and feedback

The advanced control solutions can provide millimetre-by-millimetre control of the actuators. Accurate positioning of windows is necessary to obtain an optimal indoor climate during all seasons and all weather conditions. Research studies have shown that even a minor change in the window position will have significant influence on the indoor climate – especially on windy days. Data communication between the actuators and the MotorControllers enables the actuators to report back their precise position. This enables the BMS system to know the exact position of the vents at all times.

The registration of the exact position of the windows enables the BMS system to accurately position the windows to ensure that they are open to the same amount which maintains the external appearance

of the facade. This also prevents the BMS system having to close the windows at numerous times during the day in order to reset their position to the fully closed position, preventing so called “hunting” of actuators is also a benefit of this feature.

2

Three speed operation

The WindowMaster actuators equipped with the special MotorLink® technology enable different opening/closing speeds to be used, dependent upon the digital command received. For instance a slow and soundless speed when in automatic mode and a faster more audible speed when activated by the manual keypads in order to provide an immediate visual response to the user. This technology makes it possible to operate automatic (slow speed and soundless) during lessons in schools, meetings etc.

3

Genuine synchronisation

The MotorLink® actuators can run fully synchronised – without an external synchronisation module. Up to four actuators can work together on one window with a tolerance of less than 2 mm. Through our patented solution the actuators communicate with each other directly and adjust their speed so that they are always operating fully synchronised. This genuine real time synchronisation is the best guarantee that the window is not, for example, damaged by actuators running at different speeds.

4

Reversing function

The WindowMaster actuators include an integrated reversing function, which enables the pressure on the window gaskets to be released by a few millimetres after the windows have been closed. This ensures a prolonged life span of the gaskets and air-tightness of the window. The distance which the window actuators reverse can be programmed individually

5

for each window and adjusted after installation if required. The reverse function ensures that the windows gaskets are not destroyed by the closing force of the actuator.

Pressure safety function

Window actuators equipped with the special MotorLink® technology can reduce the risk of entrapment. The actuators are programmed to stop and reverse if they encounter obstacles when closing. The set points determining when the actuators are to reverse are adjustable, but there is a limit to how sensitive they can be set as they still need to overcome the forces required to close and seal the window. In addition, other external systems can be linked to the actuators, e.g. motion sensors or safety edges. This safety function reduces the risk of anything becoming trapped in the window.

6

Fault indication

Actuators from WindowMaster using the special MotorLink® technology include a two-way communication between the MotorController and the individual window actuator. Feedback from every window actuator can provide an early indication of any potential faults. This feature makes it very easy for the caretaker or facilities manager to locate any fault in the system.

7

Online parameter set-up

Online parameter set-up, either from a maintenance terminal in the building or remotely via the internet or modem, is a standard feature in all MotorLink® solutions. Therefore initial set-up and future adjustments to the speed and forces etc. of the actuators is quickly and easily achieved. The on-line parameter set-up greatly reduces the hours needed for commissioning the system.

MotorLink® technology

The MotorControllers and smoke panels consists of a power transformer and either modules or sections. Each module or section secures the interface between motorlines (up to 36) and the field bus.

Position is stored in the non-volatile memory in the actuator PCB during power loss. Actuator position and state is transmitted to the BMS system via the motor control modules.

Actuators in a group or on a motorline are connected in parallel and operate 100% synchronised.

MotorController /
smoke panel

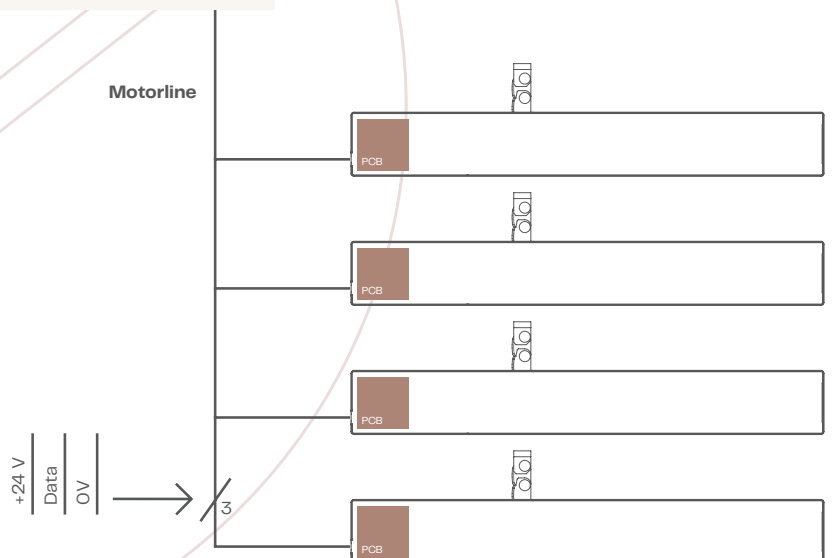

All WindowMaster MotorLink® field bus solutions support data objects giving options for position control with different speed and priority as well as feedback of actual position and detailed status of the connected actuators.

If a maximum position signal is received, the window can only be opened up to that limit. If a hand position command is received, the automatic operation position commands will be overridden for a given time. Other parameters decide which speed the actuators use – typically lower speed settings are used for automatic control in order to achieve an almost soundless operation. There is a faster and more audible speed via manual operation.

Dependent of the characteristics of the field bus in question further data objects and parameters are available. Further information can be found in the product documentation for the components.

Field-bus inter-working Principles

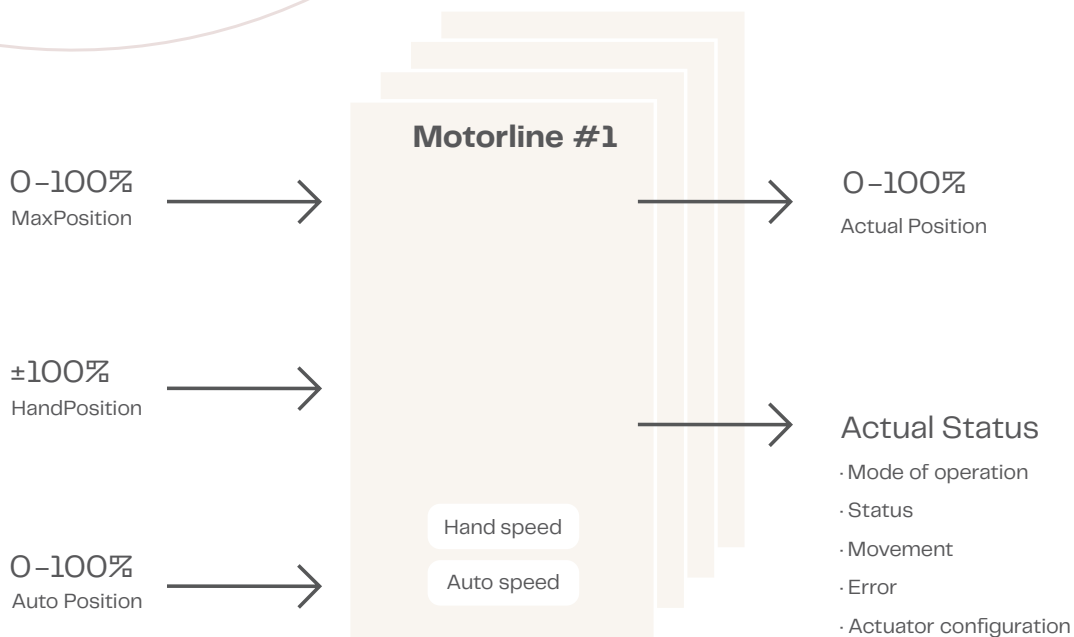

Components for a MotorLink® solution

For the intelligent control of windows, you will need both MotorLink® controls and MotorLink® actuators

Depending on whether it is comfort ventilation or combined comfort and smoke ventilation, determines which control panels to use.

MotorControllers and smoke panels can be supplied with bus protocols for the most common open standards: KNX, LON, BACnet and Modbus.

All actuators are compatible with $\pm 24V$ control units, MotorLink® MotorControllers and smoke panels

1. Outdoor sensors

Outdoor sensors are placed strategically on the outside of the building. Wind/rain sensors are used for detecting wind respectively rain, while weather stations collect climate information on temperature, humidity, rain/precipitation, wind speed and direction. The weather station is also equipped with a real time clock, which is updated by the GPS.

2. Actuators

Our actuators are available in a wide range of models and sizes and can in some cases be concealed in the window profile. The product catalogue contains both chain and spindle actuators with a stroke of 100–1000 mm which can be programmed for each window. The actuators include the MotorLink® technology.

3. Controls – comfort ventilation

WindowMaster has developed a range of MotorControllers, that interface between the intelligent WindowMaster actuators and the BMS systems. The window actuators open and close automatically with millimetre precision via a signal from the MotorController which uses the unique MotorLink® technology. The MotorControllers is available in various models for different numbers of motor lines.

4. Controls – smoke ventilation

WindowMasters smoke control panels can control the combination of comfort and smoke ventilation. Small and medium sized buildings use the CompactSmoke™ series. The FlexiSmoke™ series is designed for larger buildings, and to utilize the MotorLink® technology, require a specific module. Both series can be configured into master-/slave-combinations.

5. Indoor sensors

Each climate zone has a sensor measuring the room temperature, CO₂ level and humidity to ensure that the indoor climate is continuously regulated. A PIR detector can also be installed so that the system is able to register any activity in the zone.

6. Keypads

A keypad (switch) on the wall enables the user to temporary override the system manually, e.g. to open/close the windows. The keypads can also be linked to other functions such as sun screening.

7. Accessories

WindowMaster also supplies various optional extras for the system such as components for heating control, mechanical ventilation and sun screening.

Simple solution example

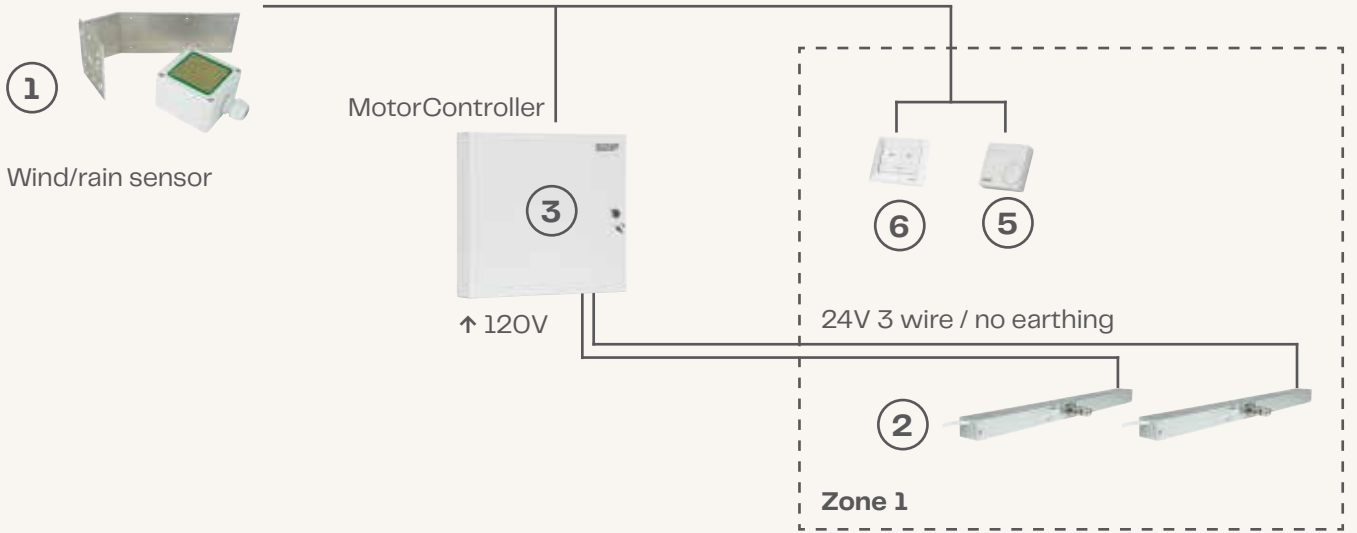

BMS Integrated solution example

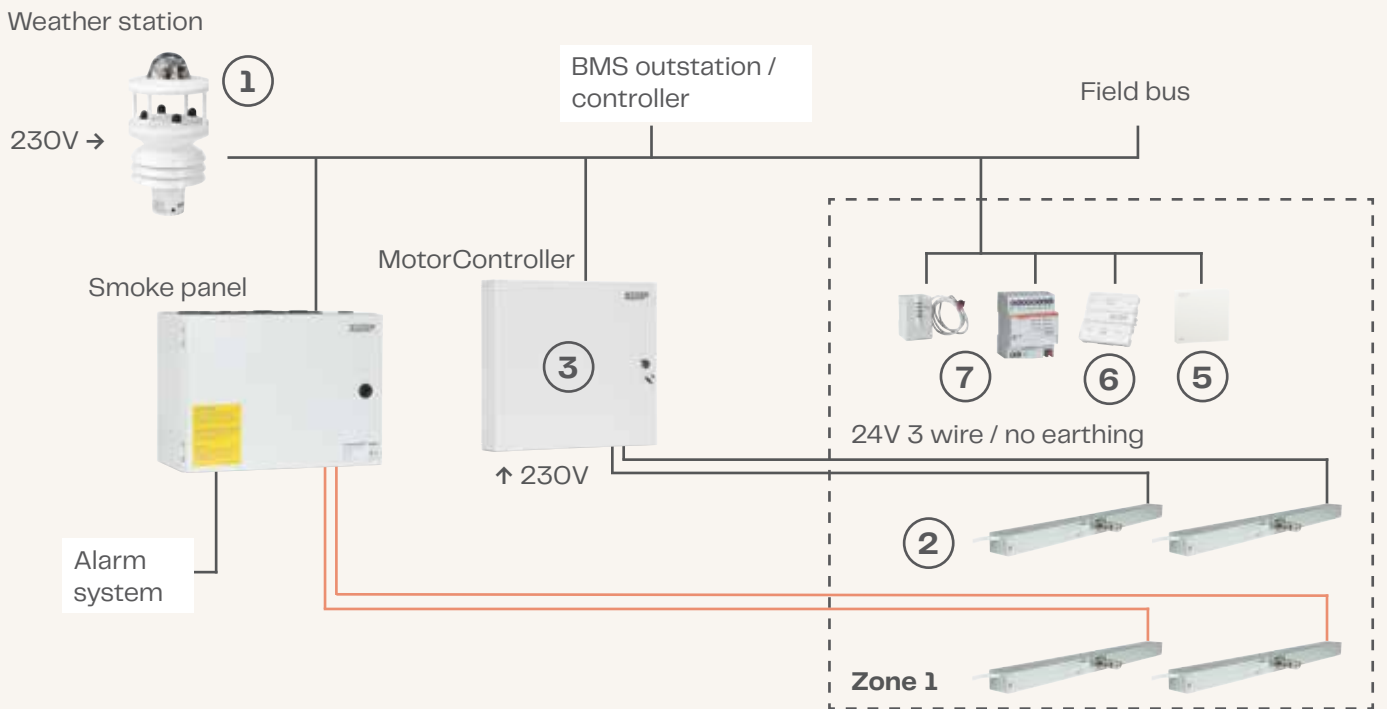

Smoke ventilation

For some buildings there is a statutory requirement for installation of smoke ventilation solutions based on automatic opening or closing of specific windows to ensure that people are able to escape the building safely

Smoke ventilation removes smoke and heat from a burning building and keeps escape routes and fire services access areas free of smoke. Smoke ventilation can save lives because the majority of fatalities in fires are caused by smoke inhalation and not by the fire itself.

Some functions from the MotorLink® technology, including fault indication, can be used advantageously in a smoke ventilation solution.

For further information and references please visit our website windowmaster.com

Legislation



It is important to note that different countries and governing authorities have differing requirements for smoke ventilation in various building types. These requirements depend on whether the building is a new-build or renovation and apply to product choice, installation and subsequent inspection and testing.

WindowMaster has comprehensive experience in providing expert advice in the design, installation and servicing of smoke ventilation solutions. We have worked with a wide range of window and facade manufacturers to develop, test and certify solutions that meet the latest requirements laid down in European standard EN 12101-2.

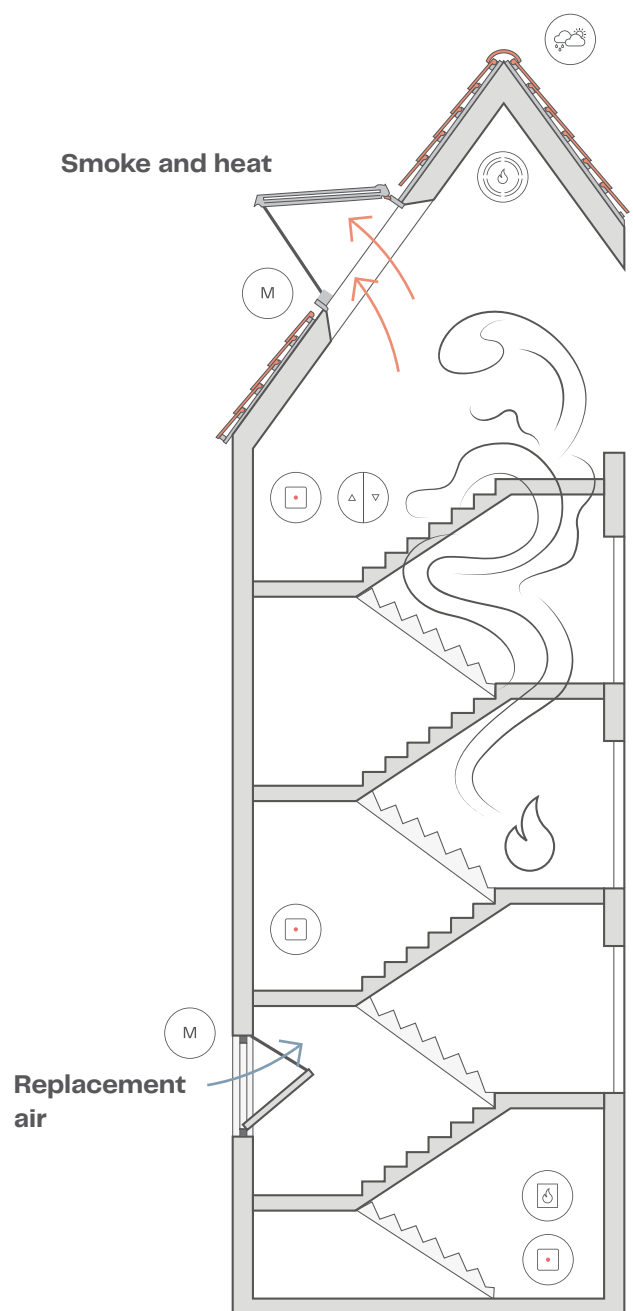

Actuator variations on a MotorLink® Motorline

The MotorController, and the smoke panel are used to control a range of individual motor lines dependent upon which panel is selected. The number of actuators that can be connected to each motor line depends on the type of actuator. The figure below shows an example with four motor lines, each shown with variations of actuators.

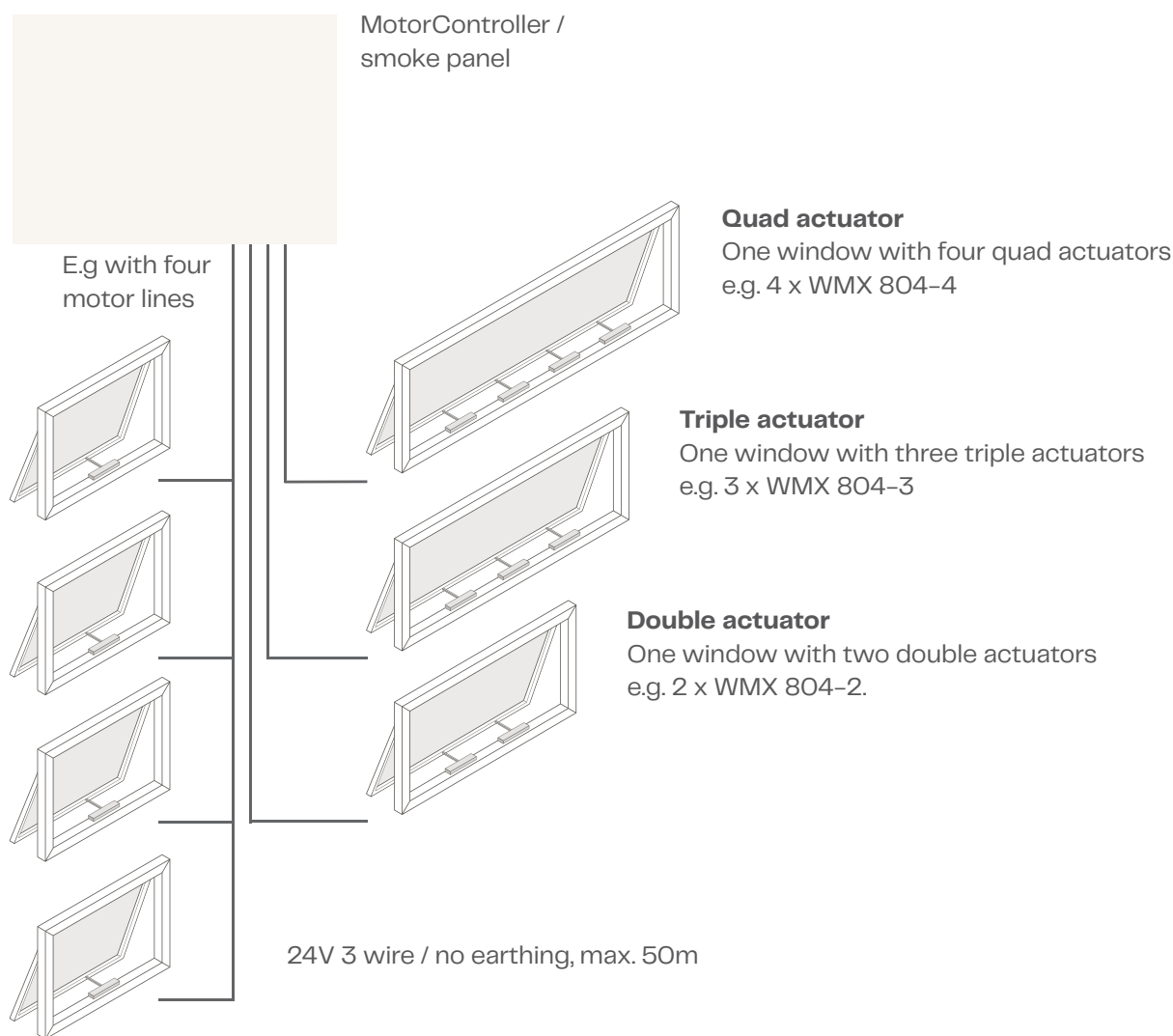

Single actuator

One window with one single actuator
e.g. 1 x WMX 804-1.

Up to four windows each with one actuator
(e.g. 4 x WMX 804-1 can be connected.)



Basic ventilation principles

Photo: Andrew HATFIELD

The driving forces in natural ventilation are thermal buoyancy and wind pressure on buildings. The design of the building, the form of the window openings and location have a significant impact on the quality of the indoor climate

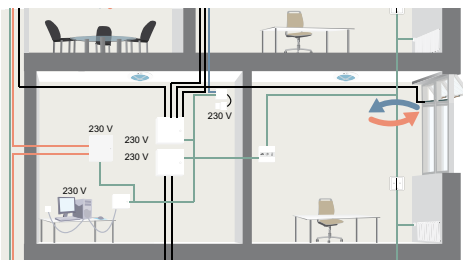

Single-sided ventilation

The windows can only be opened in one side of the room. The amount of fresh air coming into the room is limited by single-sided ventilation. It is recommended that the depth of the room should not exceed 2.5 times the clear height of the room and that the space is not used for high density spaces such as meeting rooms, classrooms or similar.

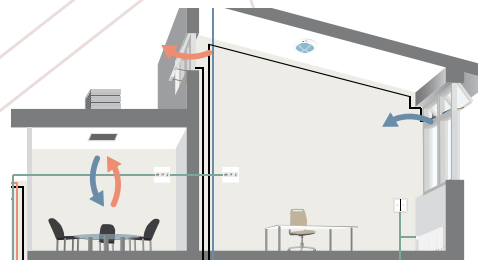

Cross-ventilation

Windows in two or more façades can create cross-ventilation in a room. The ventilation is powered primarily by the wind, which creates differences in wind pressure on the façades in which the window openings are located.

As a rule of thumb cross-ventilation can be used effectively when the depth of the room is up to 5 times the clear height of the room.

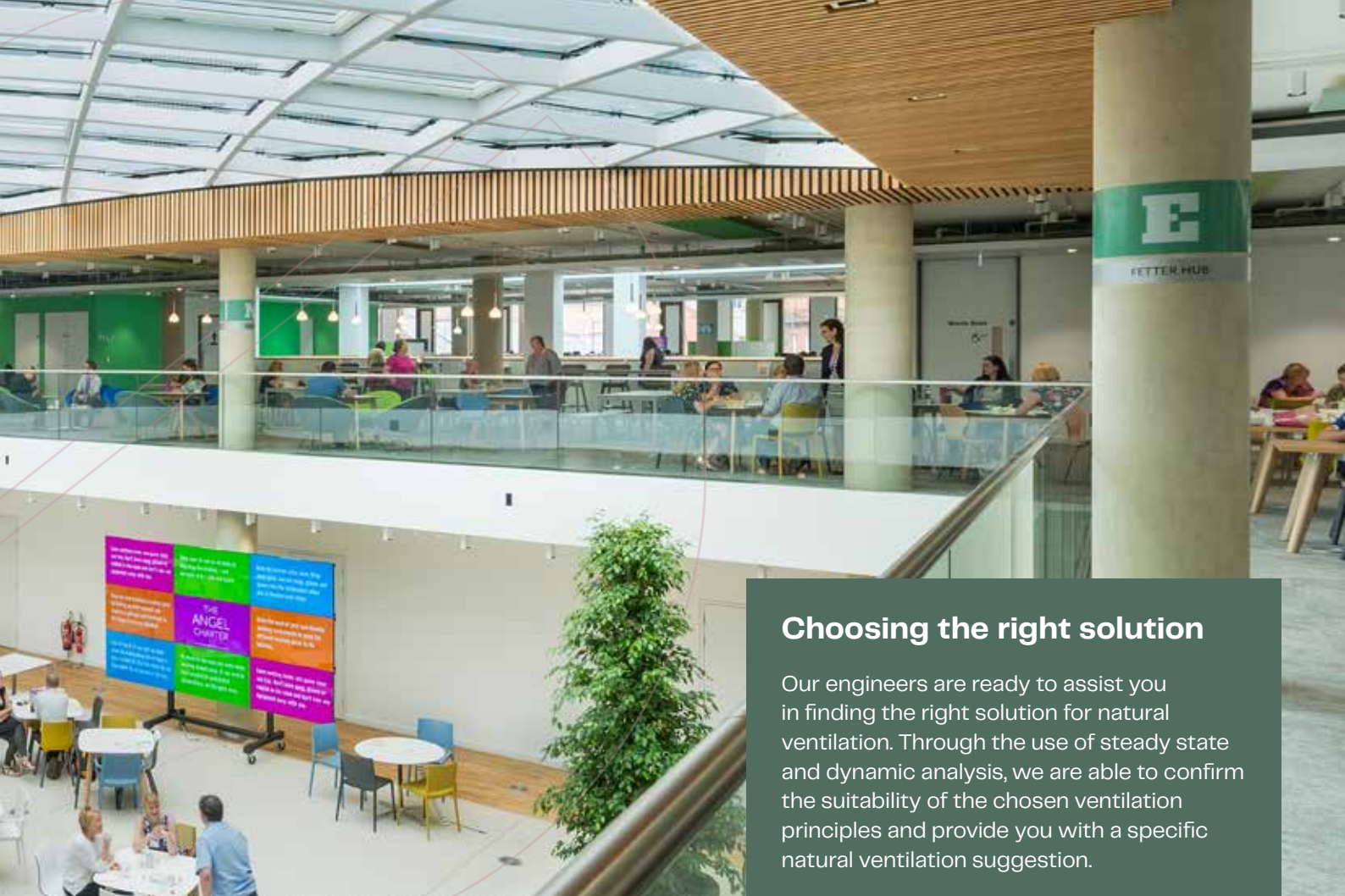

Choosing the right solution

Our engineers are ready to assist you in finding the right solution for natural ventilation. Through the use of steady state and dynamic analysis, we are able to confirm the suitability of the chosen ventilation principles and provide you with a specific natural ventilation suggestion.

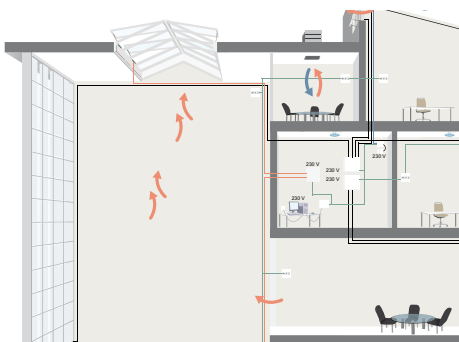

Stack-ventilation

Stack-ventilation occurs when there is a height difference between openings – i.e. between façade and roof windows. This type of ventilation is primarily driven by warm air rising to the top, whereby it creates a pressure difference which drives the ventilation. As a principle rule stack-ventilation can be used effectively when the depth of the room is up to 5 times the clear height of the room. The best effect is obtained when the openings for natural ventilation are placed so that the wind pressure contributes to an increase in the driving pressure.

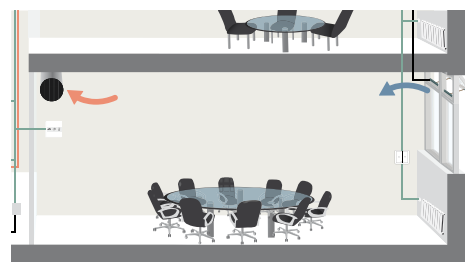

Mixed mode ventilation

In a number of projects you may choose to install a Mixed mode ventilation solution that exploits the advantages of natural ventilation and support these with mechanical ventilation. Natural ventilation is used for most of the year to ensure a flow of fresh air and to cool the building, while the mechanical ventilation – usually with heat recovery – is used in the cold winter months to reduce the heat loss in the building and to pre-heat the fresh air supply. Mixed mode ventilation solutions can come in many different formats.

Recommendations for design with natural ventilation

- It is important that the automatically controlled windows are positioned as high within the facade of the space as is possible.
- Experience has shown that it is also important for users to have the facility to locally override the automated openings, via individual switches, when greater or less opening of the windows is desired.
- In buildings with natural ventilation the height of the room should be at least 2.5 m and preferably slightly higher for the best indoor climate.
- The automatic windows should ideally be top-hung outward opening or bottom-hung inward opening and have a height of 400-500 mm.

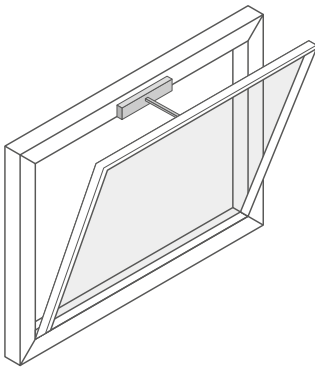

Bottom-hung inward opening

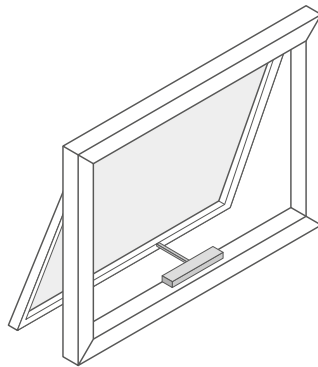

Top-hung outward opening

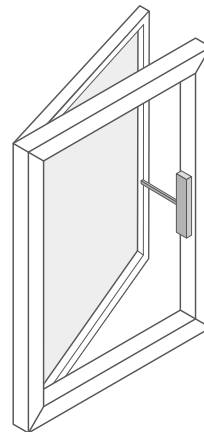

Side-hung outward opening

For other types of windows, please contact us

Matching window actuator and profile

Our engineers are happy to provide proposals for concealed, partially concealed or surface mounted solutions. We can provide proposals, for example, for how to customise the window profile to achieve the optimum integrated solution between actuator and profile

Research and development towards a sustainable indoor climate

For more than 15 years WindowMaster has worked closely together with schools, universities and research institutions on the development and optimisation of indoor climate solutions based on natural ventilation and mixed mode ventilation.

Selected research projects



Aalborg University, in collaboration with WindowMaster, developed a number of basic principles, algorithms and parameters for optimal control of natural ventilation. Aalborg University and WindowMaster have carried out a series of tests and analysis of air movement around windows to determine the influence of the window location in the facade on the indoor climate.



The Engineering College of Aarhus has, in collaboration with WindowMaster, analyzed the energy consumption, investment and operating costs for typical office buildings. The analysis is done for a number of different types of indoor climate solutions – natural ventilation and mechanical ventilation.



The Alexandra Institute and the Engineering College in Aarhus have carried out a research project supported by EBST entitled "Minimum Configuration – Home Automation" in collaboration with several companies including WindowMaster. The project focuses particularly on user involvement and innovation concerning automatic control devices in homes to achieve energy savings.



In collaboration with the International Center for Indoor Environment and Energy at the Technical University of Denmark, WindowMaster has supported a three-year Ph.D. project 'Occupant behavior with regard to control of the indoor environment'. The purpose of the project has been to study and analyse the users' perception of indoor climate.



The Technological Institute in Copenhagen has, in collaboration with WindowMaster, conducted life cycle analysis for different indoor climate solutions – natural ventilation, mixed mode ventilation and mechanical ventilation. Based on the analysis, an evaluation has been made as to which solution in total has the smallest environmental impact related to production, installation, operation and disposal.

The collaboration with various institutions contributes valuable knowledge about user needs, user behavior, users' perception of a good indoor climate, software, life cycle analysis and much more. Elements which, together with a dedicated effort by our own development department, have made it possible to create products and solutions that ensure a good indoor climate using the fewest possible resources.

WindowMaster aspires to protect people and the environment by creating a healthy and safe indoor climate, automatically ventilating spaces with fresh air through facade and roof windows in commercial buildings. We offer the construction industry foresighted, flexible and intelligent window actuators and control systems for natural ventilation, mixed mode ventilation and smoke ventilation – of the highest quality.

WindowMaster employs highly experienced cleantech specialists in Denmark, Norway, Germany, United Kingdom, Ireland, Switzerland and United States of America. In addition, we work with a vast network of certified partners. With our extensive expertise built up since 1990, WindowMaster is ready to help the construction industry meet its green obligations and achieve their architectural and technical ambitions.

MotorLink® is the unique standard in communication between BMS systems and electrical window actuators for all building types. MotorLink® is extremely flexible and interfaces to all major international bus-communication standards – KNX, LON, BACnet and Modbus.

[windowmaster.com](https://www.windowmaster.com)